

# HYDROLUTION PRO, THE SYSTEM TO HEATING AND COOLING

R32

GWP  
675

50 KW

e-3D

NEW  
COMPRESSOR  
E-3D SCROLL



# HYDROLUTION PRO HEATING AND COOLING AT MAXIMUM PERFORMANCE

HYDROLUTION PRO is a latest-generation monoblock heat pump, designed for industrial applications.

It is equipped with an advanced compressor and ecological R32 refrigerant, its exceptional performance stands out, significantly reducing the environmental impact compared to traditional systems.

With 5 different versions, it is able to adapt to any type of system, ensuring efficiency and versatility. Its very low R32 charge makes it an ecological and sustainable choice.

## HIGH EFFICIENCY

- Class A+++ in heating with flow water temperature at 35° C.



With delivery temperature at 35°C

## ENVIRONMENTALLY RESPONSIBLE

- Ecological, as it guarantees low environmental impact and silent operation.



For all power sizes

## TOP EFFICIENCY

- SCOP 4.59 in heating.
- The compressor is designed to be efficient up to -20° C, it is suitable for the coldest climates, in cooling the efficient operation of the machine is guaranteed up to 43° C.



Heating operation up to -20° C



Delivery water at 4° C up to 43° C external



SCOP heating

## ADVANTAGES

- Suitable for underfloor heating, fan coil and radiator systems.
- Modular solution up to 1000 kW.
- Long-term reliability.
- When using Hot Water or Q-ton for ACS, possibility of eliminating methane altogether.
- Low management costs.

# HYDROLUTION PRO

## New e-3D Scroll compressor

New technology uses EC fan for maximum efficiency and energy saving.

- World-unique compression process design.
- Improved energy efficiency with exceptional low-speed performance.
- Significant increase in compressor efficiency.

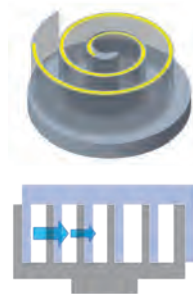

NORMAL SCROLL



NEW E-3D SCROLL FOR MSV2

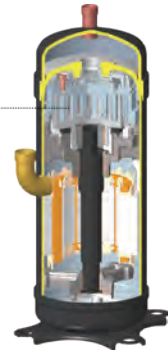

## Wide range of applications

Cooling operation with incoming air at 43° C.

### HEATING

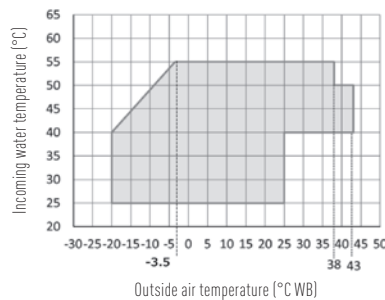

### COOLING

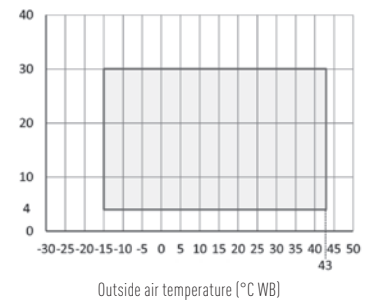

REMOTE CONTROL RC-MCU-E



ADVANCED CONTROL MCU-C-E

- A wired controller can be connected to up to 20 MCUS, which, with the same operating mode, will work with the same parameters.
- Control of mixed Heating/Cooling operation when there are multiple MCUS connected to the same system.
- It is possible to set a yearly schedule consisting of up to six different patterns.
- It is possible to display capacity and COP.
- Store the cooling/heating temperature settings separately.
- Display and reset the Error log.

- Allows control of up to 20 units.
- Optimally controls the number of machines to be used based on the load.
- Management of the bypass valve.
- Allows control of a secondary circulation pump.
- Optimization of compressor hours, the operating priority falls on the machine with the least active working hours. Maximization of the useful life of the components.

# HYDROLUTION PRO

## Easy operation

With the easy-to-use RC-MCU-E wired controller, adjusting settings becomes a breeze. The advanced MCU-C-E control takes care of optimizing unit operation based on load.

To meet the varying seasonal demand for hot and cold water, the system allows the number of cooling and heating units to be adjusted based on the operating season and load.

In addition, a mixed operation setting for cooling and heating can be configured effortlessly using the calendar function on the wired controller. This feature allows users to create optimized management plans for facilities.

## Simultaneous heating and cooling

The system allows simultaneous heating and cooling with two-pipe terminals, thanks to advanced programming via the control panel. This allows you to configure and adjust, based on specific needs, the units in hot and/or cold mode within the same system.

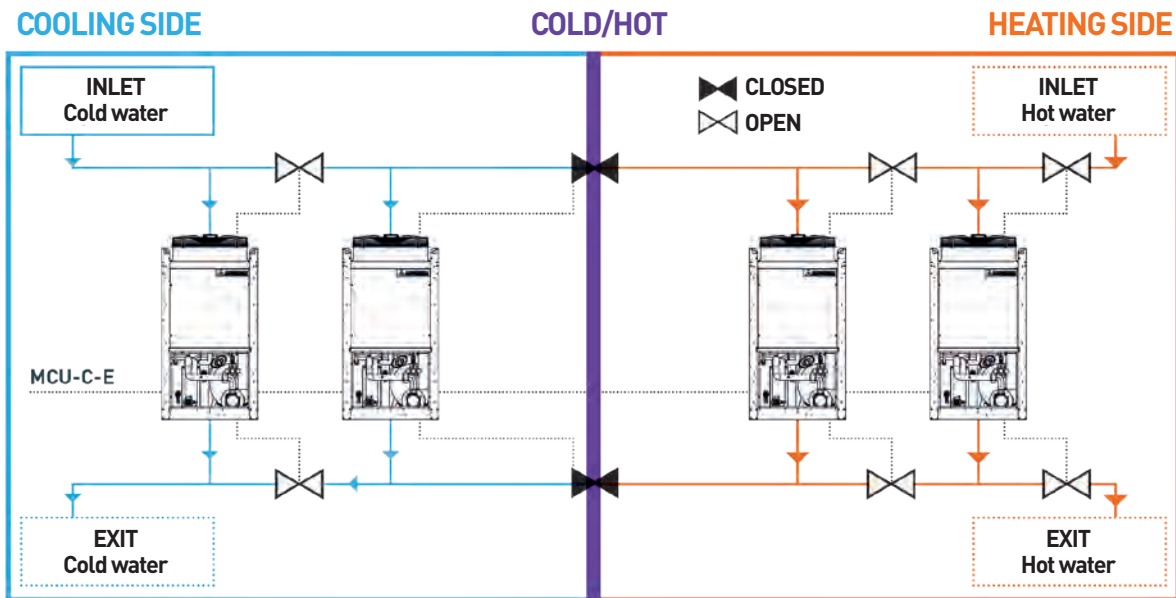

Controller unit (MCU-C-E) manages the units in cooling.

The cooling/heating mixing mode can be set according to the season. 6 different annual patterns can be set by programming the wired controller (RC-MCU-E).

Controller unit (MCU-C-E) manages the units in heating.



**Controller MCU**  
By adding an MCU controller, intelligent management of operating hours is possible, so that they balance out across all units in the group.



# HYDROLUTION PRO

## MCUS 5001 VHE-W

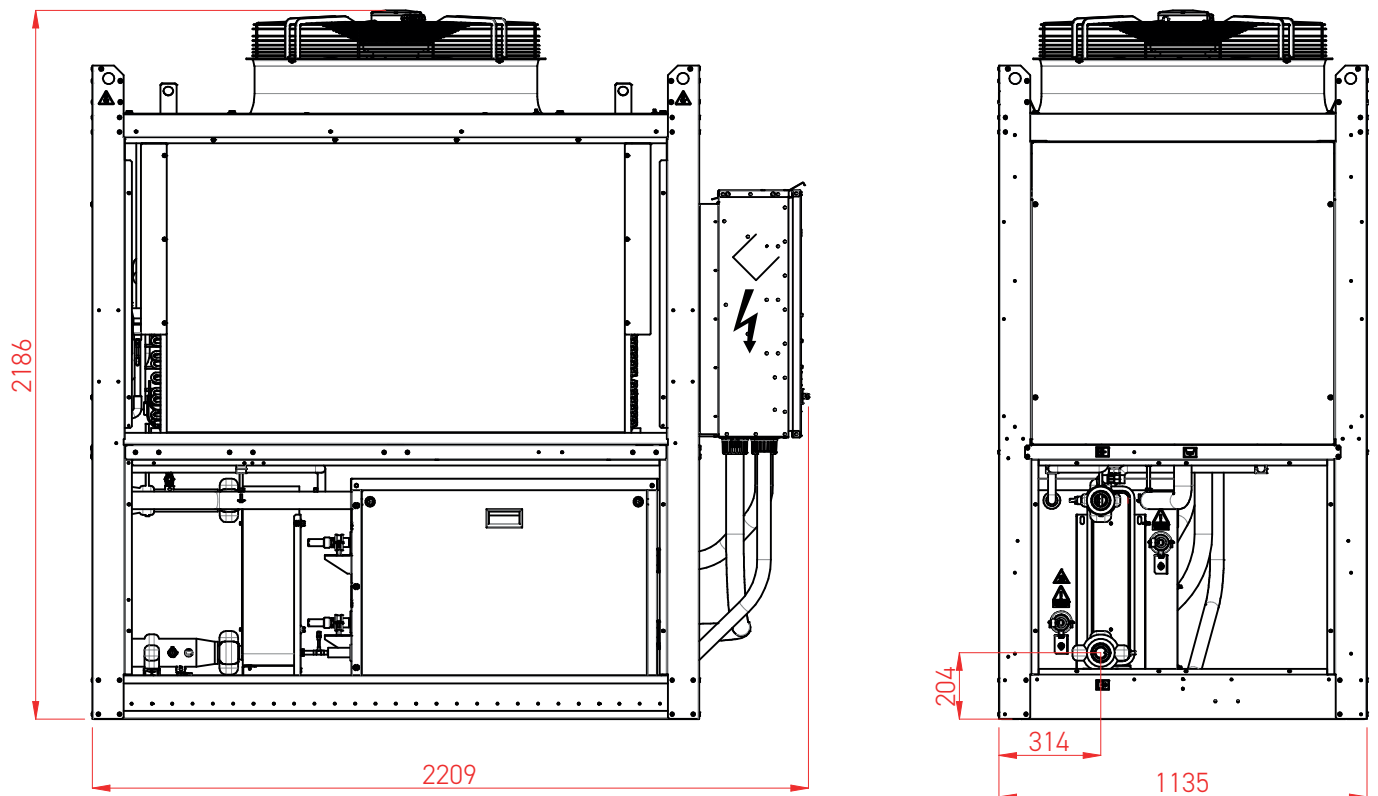

All measurements are expressed in mm.  
The indicated dimensions are valid for all models.

50 kW models	Model	Configuration
	MCUS 5001 VHE-W	Without pump
	MCUS 5001 VHE-W1	Integrated LP pump
	MCUS 5001 VHE-W1A	Integrated LP pump + buffer tank
	MCUS 5001 VHE-W2	Integrated HP pump
	MCUS 5001 VHE-W2A	Integrated HP pump + buffer tank

FUNCTIONALITY	APPLICATIONS	ADVANTAGES FOR PROFESSIONALS	ADVANTAGES FOR CUSTOMERS
<ul style="list-style-type: none"> <li>• underfloor heating</li> <li>• fan coil heating</li> <li>• high efficiency radiator</li> <li>• heating</li> <li>• cooling</li> </ul>	<ul style="list-style-type: none"> <li>• condominium</li> <li>• office building</li> <li>• shopping center</li> </ul>	<ul style="list-style-type: none"> <li>• installation flexibility</li> <li>• low environmental impact</li> <li>• modular solution up to 1000 kW</li> </ul>	<ul style="list-style-type: none"> <li>• very high performance</li> <li>• long-term reliability</li> <li>• when using Hot Water or Q-ton for ACS, possibility of eliminating methane altogether</li> <li>• low management costs</li> </ul>

## TECHNICAL DATA

## HYDROLUTION PRO

Outdoor unit model				MCUS 5001 VHE-W
Heating	Rated power	A7//W35	kW	50.00
	Power input			12.30
	Performance coefficient		COP	4.07
	Rated power	A7//W45	kW	47.00
	Power input			13.50
	Performance coefficient		COP	3.48
Cooling	Rated power	A35//W18	kW	50.00
	Power input			12.90
	Energy efficiency		EER	3.87
	Rated power	A35//W7	kW	44.00
	Power input			15.10
	Energy efficiency		EER	2.91
Seasonal data (Heating)	Prated @ -10°C	W35	kW	32.10
	Seasonal performance coefficient		SCOP	4.58
	Seasonal energy efficiency (I <sub>ns</sub> )		%	180
	Energy efficiency class		-	A+++
	Annual energy consumption		kWh/y	14439
Operating range	Outdoor air temperature	Heating & DHW	°C	-20-43
		Cooling		-15-43
	Delivery water temperature	Heating & DHW	°C	25-55
		Cooling		4-30
Refrigerant circuit data	Refrigerant type (GWP)			R32 (675)
	Q.ty of precharge (tons CO <sub>2</sub> )		kg (t)	6.7 (4.523)
	Refrigerant control system			Electronic expansion valve
	Compressor		type	Scroll / DC motor
Hydraulic data	Water/freon heat exchanger		type	Braze-welded plates
	Water flow rate	Min-Max	m <sup>3</sup> /h	3-13.8
		Pressure drops	Cooling	kPa
	Heating			44.5
	Water connections		type	Victaulic
	Pipe diameter	In/Out	inch	2" (DN50)
	System water volume	Min	L	1276
Operating pressure (system)	Max	bar	4	
Electrical data	Power supply		V/Ph/Hz	400/3Ph+N/50
	Maximum current		A	33
	Power cable (recommended)		type	5x10 mm <sup>2</sup>
Product specifications	Fan	Type	q.ty	Axial / EC Motor
		Air flow	m <sup>3</sup> /h	15600
	Sound power level		dB(A)	88
	Sound pressure level (a 1 m)		dB(A)	68.5
	Dimensions	LxDxH	mm	2209x1135x2186
	Weight	Net	kg	531
Control (included)				RC-MCU-E
Models with optional parts	With circulation pump	Low prevalence (LP)		MCUS 5001 VHE-W1
		High prevalence (HP)		MCUS 5001 VHE-W2
	With inertial tank1 + pump	Low prevalence (LP)		MCUS 5001 VHE-W1A
		High prevalence (HP)		MCUS 5001 VHE-W2A
Specifications optional parts	LP pump head		m	17
	HP pump head		m	27
	Inertial tank volume		L	180
	Expansion vessel volume		L	8

1. Includes expansion vessel.

The data reported above refers to the following standards: EN 14511:2018; EN 14825:2019; EN50564:2011; EN12102-1:2018; EN12102-2:2019; (EU)No:811:2013; (EU)No:813:2013; OJ 2014/C 207/02:2014.